



## BS EN 14175-3:2003 Containment Factor deciphered

Waldner Knowledge Base  
January 2011

Please let us have your feedback on this publication:  
[steffen.springer@waldner.co.uk](mailto:steffen.springer@waldner.co.uk)  
+44 7795010353

## Content

1. Definition of the Containment Factor  $C_{F1}$  according to BS EN14175
2. Interpretation of the Results
3. Discussion: Is the Containment Factor objective and conclusive when comparing fume cupboard performance (or: Is  $C_{F1}$  suitable as a specification performance / selection criteria)?
4. Summary and Conclusion
5. Sample Calculations

## Definition of Containment Factor

According to BS EN 14175-3:2003, the dimensionless containment factor  $C_{F1}$  can be **optionally** (the code does not demand the use of this factor as part of the test certification) calculated as:

$$C_{F1} = \frac{q \text{ (l/min)}}{(Q \times \varphi_1) \left( \frac{m^3}{h} \times \frac{1000}{60} \right) \times (ppm \times 10^{-6})}$$

- q ... Flow rate of tracer gas (SF<sub>6</sub> – note that the tracer gas flow rate is **only 10%** of the test gas flow rate because a mixture of 90% N<sub>2</sub> and 10% SF<sub>6</sub> is used)
- Q ... Fume cupboard extract flow rate
- Φ<sub>1</sub>... Mean tracer gas concentration as volume fraction rounded to the **second** decimal place

## Interpretation of the Results

- Structure of the equation is very simple
- Theoretically, the result means: the higher the factor the higher the containment of the fume cupboard.
- Magnitude of containment factor is dependent in three values: flow rate of tracer gas, extract flow rate of fume cupboard and mean tracer gas concentration (the latter is the only value in this equation that relates to the ability of fume cupboard to retain).
- According to EN,  $C_{F1}$  should be rounded to the nearest integer and it must be indicated “if the result is limited by the detection limit of the instrument” Why? – Just read on!

## The Big Question

**Does the containment factor deliver an objective, conclusive and independent result to judge and compare the true containment of fume cupboards (specification selection criteria)?**

## Discussion – The influence of the extract flow rate

- Q is in the denominator of the equation
- Hence, the larger Q the smaller  $C_{F1}$  will be
- Everything else being equal, this indicates a flaw. Surely, the containment of a fume cupboard will increase with increasing extract flow rates (volumes or face velocity).
- With q, the tracer gas flow rate, being always constant (stipulated in EN) and an assumed detection limit of 0.01ppm of the measuring equipment, the only variable remaining is the extract volume of the fume cupboard. Is this result ( $C_{F1}$  calculated as described before) suitable for an objective comparison of fume cupboard containment?

## Discussion – The influence of the detection limit

- The detection limit of the equipment is a crucial part of the EN testing regime as the market demands threshold values in the parts per million or even parts per billion range
- BS EN 14175 clearly stipulates that “the mean tracer gas concentration as a volume fraction of the test period” must be “calculated” and “rounded to the second decimal place”.
- Hence, if BS EN 14175 is applied, any mean tracer gas concentration value below 0.01 must be rounded to 0.01 and certified accordingly.
- In terms of the containment factor this means that certified results are dependent on the detection limit of the instrument used. Does this allow an objective (performance based) comparison / selection?

## Summary and Conclusion

- The containment factor according to BS EN 14175 depends on three variables, whereby only **one** (mean tracer gas concentration) is related to the specific ability of the fume cupboard to contain.
- The actual magnitude of the containment factor also fluctuates with the extract flow rate used **and** the detection limit of the instrument applied.
- As the illustration on the next page shows, the containment factor is **not** suitable as an objective indication for fume cupboard containment unless all models in question are tested under the same conditions, with the same extract volumes **and** with same test equipment. Only one of these variables not being the same, will lead to different containment factors. **In practical terms, the containment factor does not enable the user to select the best cupboard based on containment performance.**

## Sample Calculation

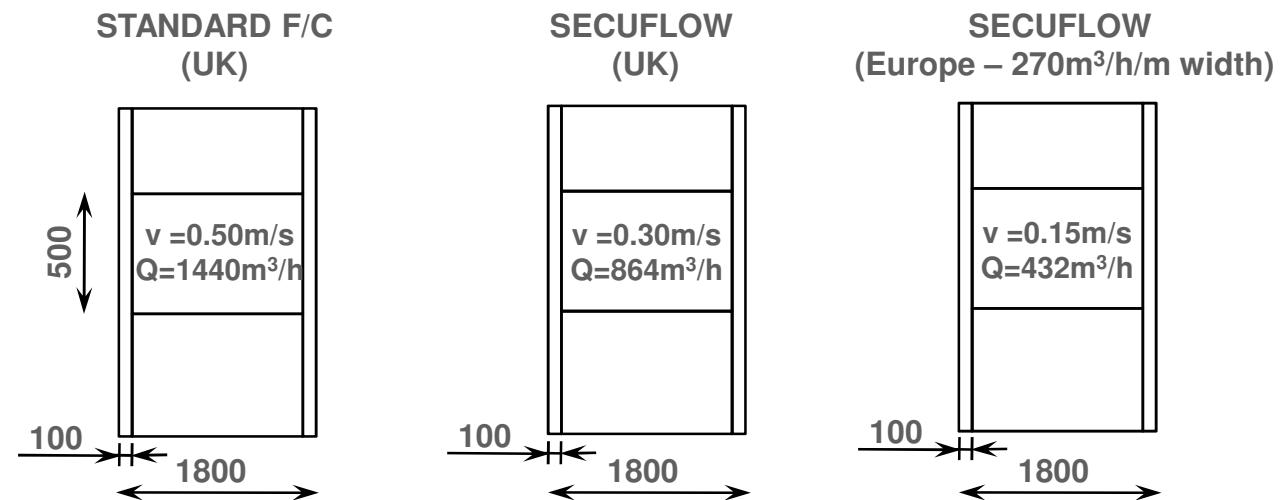

	$C_{F1}$	$C_{F1}$	$C_{F1}$
$q = 0.20 \text{ l/min}^1$ $\varphi = 0.01 \text{ ppm}^2$	833	1,389	2,778
$q = 0.20 \text{ l/min}^1$ $\varphi = 0.10 \text{ ppm}^2$	83	139	278

- 1) Tracer gas flow rate to BS EN 14175 for inner grid measurement, 2.0 l/min test gas = 0.2 l/min tracer gas (90% N<sub>2</sub> + 10% SF<sub>6</sub>)  
 2) assumed detection limit