

Low level fume cupboards

Low level fume cupboard with side installation

Intended use

- Protective device for the user, tested in acc. with EN 14175
- Extraction of fumes, aerosols and dust from the internal workspace to prevent dangerous amounts of pollutants from escaping into the laboratory
- To prevent the formation of dangerous potentially explosive atmospheres in the internal workspace
- Protection from splashes of hazardous substances
- Protection from flying particles, bodies or parts escaping from the internal workspace
- General fume cupboards constructed in acc. with EN 14175 are normally not suited for use with radioactive substances or microorganisms
- Not suitable for openly breaking down chemicals
- Suitable for experimental set-ups on an add-on table
- Service outlets in the service modules of the side panels of the internal workspace
- Control units located vertically on the side service panels

Design

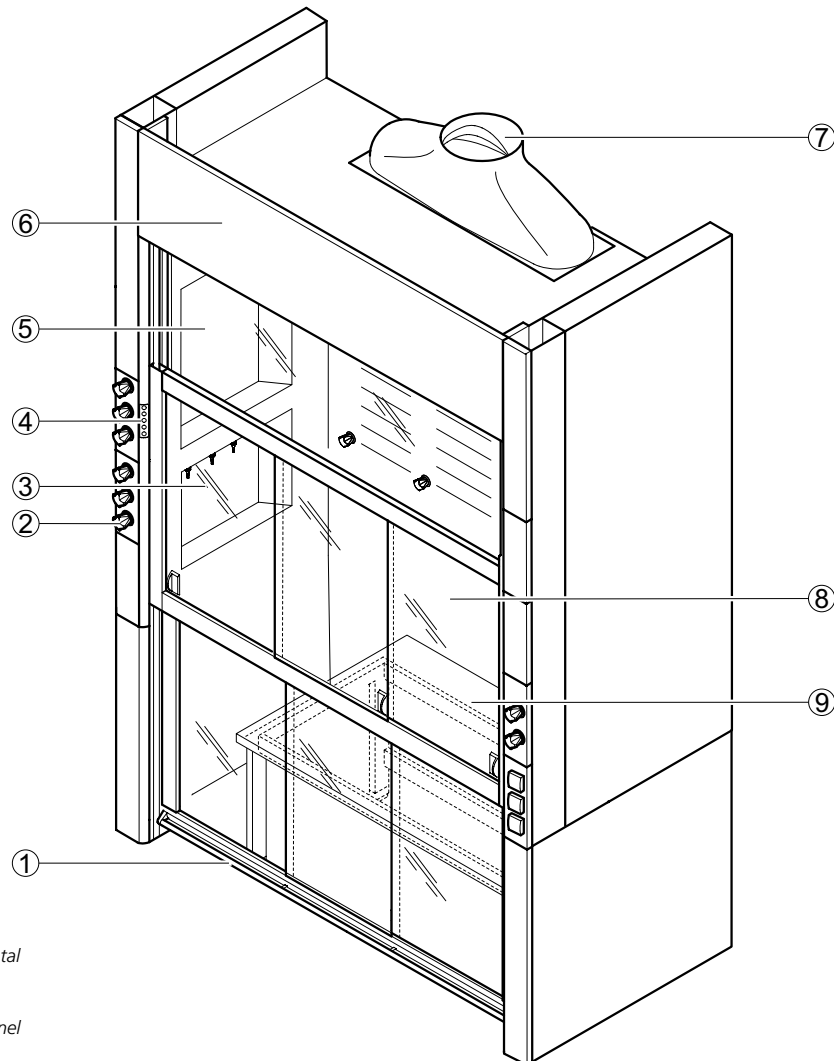

- 1 Sash with handle and horizontal sashes
- 2 Service panel
- 3 Service module in the side panel of the fume cupboard
- 4 FAZ or AC control panel
- 5 Upper sash window
- 6 Removable fascia panel
- 7 Extract manifold
- 8 Baffle with scaffold points
- 9 Add-on table

Low level fume cupboards

Low level fume cupboard with side installation

Dimensional drawing

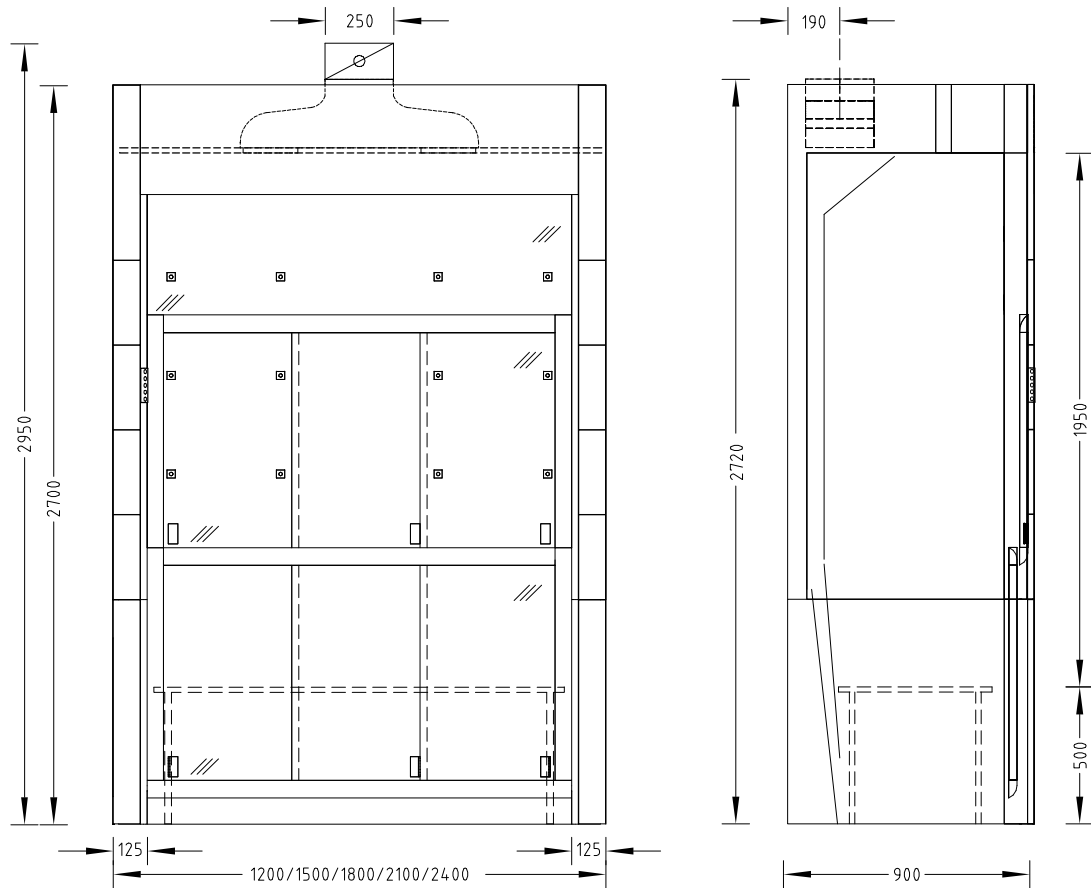

Technical data

Dimensions	1200	1500	1800	2100	2400
Width [mm]	1200	1500	1800	2100	2400
Depth [mm]	900				
Height [mm]	2700				
Clear width, internal workspace [mm]	950	1250	1550	1850	2150
Clear height, internal workspace [mm]	1950				
Add-on table with H-frame [mm]	900 x 575	1200 x 575	1500 x 575	1800 x 575	2100 x 575
Working height [mm]	500				

Weight	1200	1500	1800	2100	2400
Without installation [kg]	Approx. 320	Approx. 390	Approx. 450	Approx. 510	Approx. 570

Low level fume cupboards

Low level fume cupboard with side installation

Design characteristics	1200	1500	1800	2100	2400
Work surface	Add-on table H-frame with surrounding increased edge				
Two-piece sash	2 horizontal sashes at the top and bottom		3 horizontal sashes at the top and bottom		
Side of fume cupboard	Glass pane on the left and/or right as an option; not if service modules are installed in the side panel of the fume cupboard Material lock on the left and/or right as an option				
Number of devices for scaffold points, ø 12 to 13 mm	9		12		15
Service modules	Service modules in the left and/or right side panel of the fume cupboard, depending on requirement				

Electrics	
Electrical supply	External sockets in service panels Internal sockets in service modules
Fuse box	Optional
Sash controller SC	Optional

Sanitary technology	
Sanitary supply	Service modules with take-off valves for vacuum, gases and/or waters and integrated sink (PP) as an option

Ventilation technology	1200	1500	1800	2100	2400
Minimum air exchange rate [m ³ /h] ¹⁾	480	600	720	840	960
Function display	FAZ				
Airflow damper, constant	Airflow-Controller AC				
Airflow damper, variable	Airflow-Controller AC				
Detector of sash position	Only variable with Airflow-Controller AC				
Connection height [mm] for FAZ with extract manifold ø 250 mm	2720				
Connection height [mm] for FAZ with extract manifold ø 315 mm ²⁾	2830				
Connection height [mm] for AC with extract manifold ø 250 mm	2950				
Connection height [mm] for AC with extract manifold ø 315 mm ²⁾	3070				
Underbench exhaust	As an option, depending on requirements and regulations				

¹⁾ All air volume specifications refer to an opening height of the sash window of 500 mm (test opening in acc. with EN 14175) and the maximum tracer gas values recommended by German Standard (BG Chemie). Shown rates correspond to a face velocity of 0.24 m/s. For other design face velocities, please contact your Waldner sales representative.

²⁾ In order to minimise noise and pressure losses, for air volumes >1000 m³/h Waldner recommends using the extract manifold with a connection diameter of 315 mm.

A maximum admission pressure of 600 Pa should not be exceeded in the case of fume cupboards with airflow dampers.

The indicated minimum air exchange rates were determined under specified test conditions in acc. with EN 14175-3. These minimum air exchange rates must be adapted when dimensioning the ventilation system.

If on-site extract air monitoring systems or airflow dampers are used, the required air volumes may be different. The operating limitations must be agreed upon with Waldner.

Material	
Worktop H-frame with surrounding increased edge	Polypropylene Epoxy Stoneware Stainless steel
Internal lining	Solid grade laminate Melamine resin facing