

Service wing

Intended use

- Laboratory areas with technical devices for services
- Services supply and disposal via the ceiling for:
 - ▶ Laboratory benches and sinks below the service wing
 - ▶ Local extraction devices and AeroEm fume cupboard
 - ▶ Laboratory equipment on mobile tables or underbench constructions
 - ▶ Floor-mounted laboratory equipment
- Tool-free installation of supplementary service wing add-on parts

Design

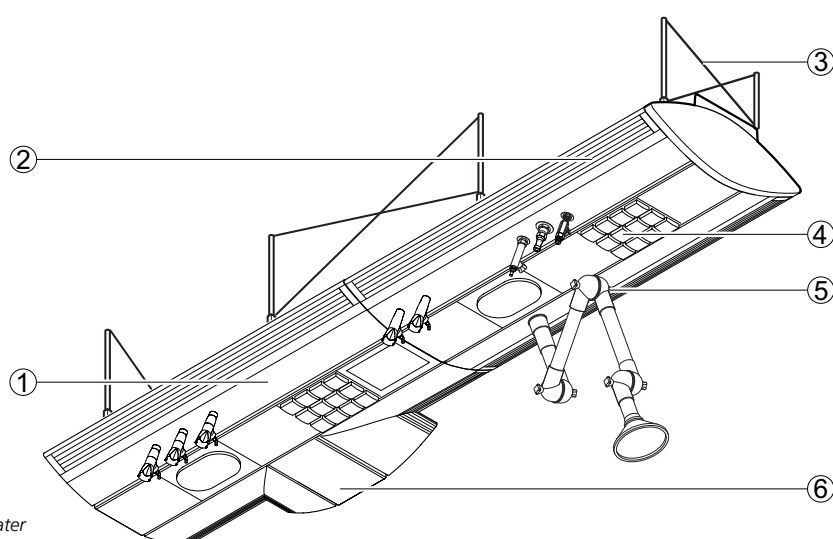

- 1 Sanitary duct with gas and water taps
- 2 Wing edge (lamp or moulded part)
- 3 Braced support
- 4 Electrical trunking with electrical connections
- 5 Ventilation duct with local extraction
- 6 T wing element

Expansion stage 1

- Electrical trunking with service panels for the power supply

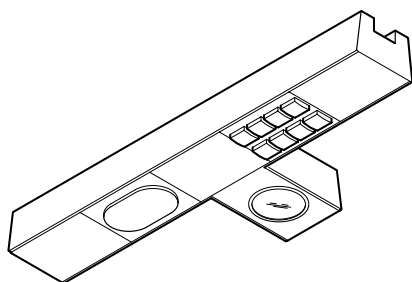

Expansion stage 2

- Electrical trunking with service panels for the power supply
- Wing edge designed as a lamp

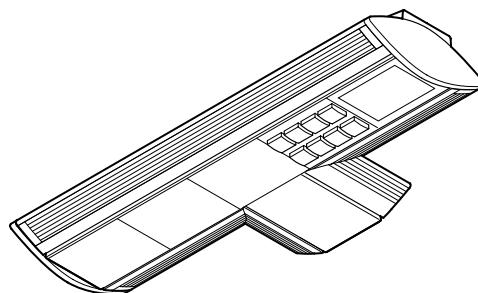

Expansion stage 3

- Electrical trunking with service panels for the power supply
- Sanitary duct
- Ventilation duct
- Wing edge designed as a lamp

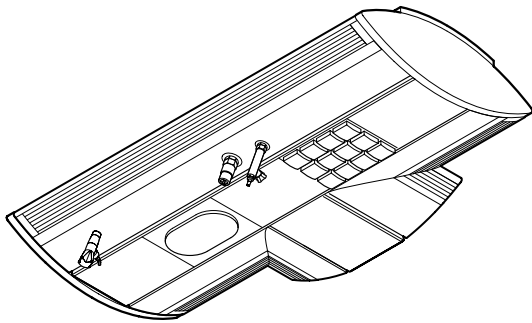
**Expansion stage 4**

- Electrical trunking with service panels for the power supply
- Sanitary duct
- Ventilation duct
- Wing edge designed as an accessory for the sanitary and ventilation routing

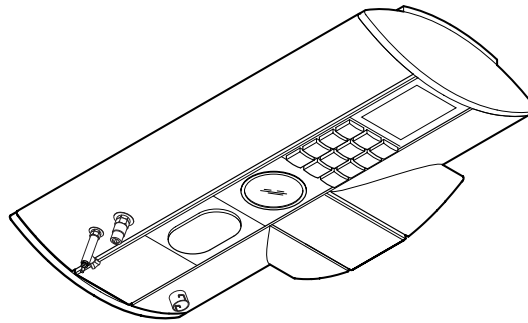
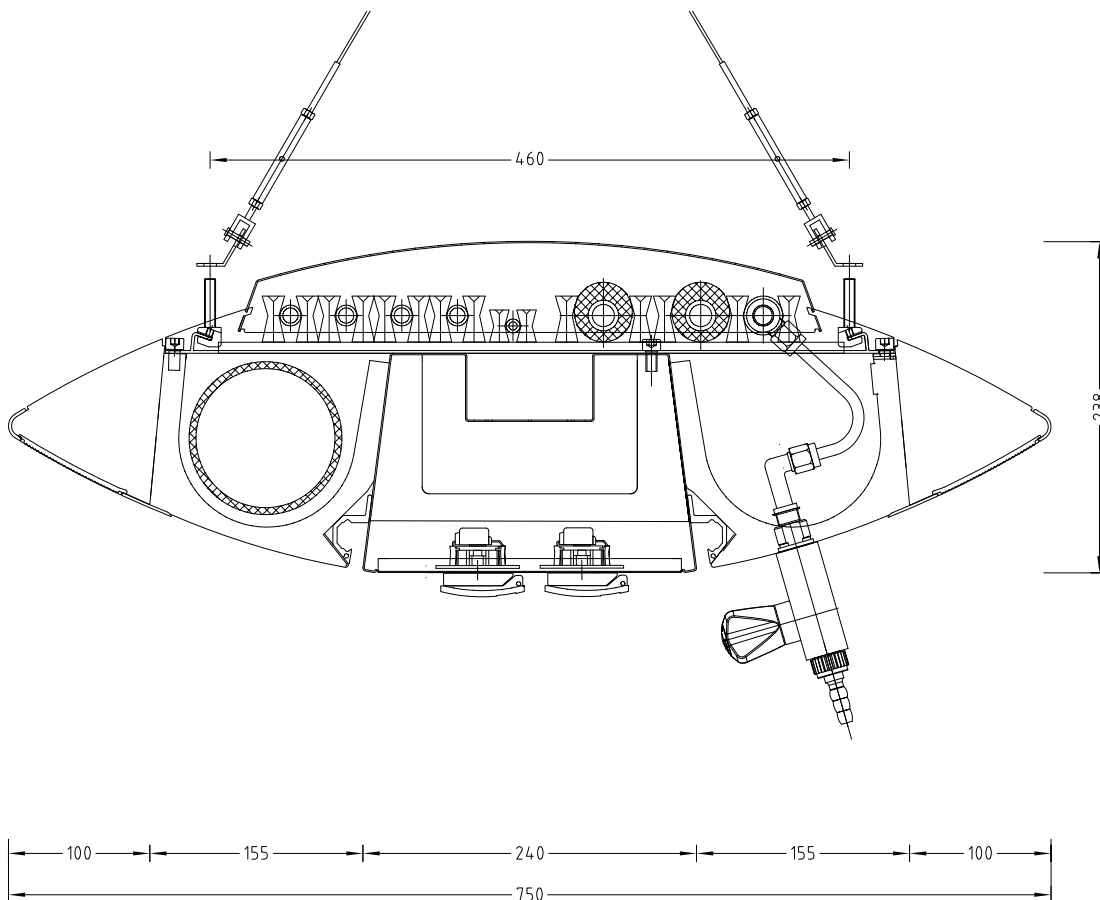
**Dimensional drawing****Service wing, expansion stage 3**

Service wing

Technical data

Dimensions				
Width [mm]	600	900	1200	1500
Depth [mm] with expansion stage 1	240			
Depth [mm] with expansion stage 2	496			
Depth [mm] with expansion stages 3 and 4	750			
Height [mm] without dust cover for expansion stages 1 and 2	181			
Height [mm] without dust cover for expansion stages 3 and 4	191			

Load bearing capacity	
Maximum permissible load [kg]	120

Design characteristics	
Construction	Feeding, wing, T-element as an option Flexible bracing to prevent vibrations Can be equipped on both sides Dust protection through grid elements installed above

Electrics	
Electrical supply	Electrical trunking with service panels for the power supply Connections for telephone, computer, monitor and loudspeaker as an option
Lighting	Lamps integrated in wing edges (direct and indirect lighting) as well as down light in the electrical trunking as an option
Fuse box	Optional

Sanitary technology	
Sanitary supply	Service panels with take-off valves for vacuum, gases and/or waters Supply pipes and cables, ventilation duct guiding Local extraction system and/or extract air spigot for AeroEM as an option