

Special tables

Add-on table for low level fume cupboards

Intended use

- For adding to low level fume cupboards
- Bench frame with worktop made of various materials as a work surface and storage area for laboratory work
- Supporting construction for analytical equipment and superstructures

Design

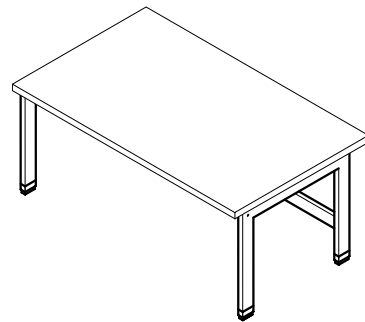

Technical data

Dimensions					
Width [mm]	900	1200	1500	1800	2100
Depth [mm]	600				
Working height [mm]	500				

Material	
Bench frame	Steel profile 60/25/2 mm
Worktop	Depending on requirement
Height-adjustable feet	Plastic housing with steel spindle

Load bearing capacity	
H-frame [kg]	200

Design characteristics	
Worktop	Surrounding increased edge
Height-adjustable feet	Individually adjustable

Special tables

Balance table

Intended use

- For setting up analytical balances and other sensitive measuring equipment
- Bench frame with worktop and specially mounted, vibration-free plate

Design

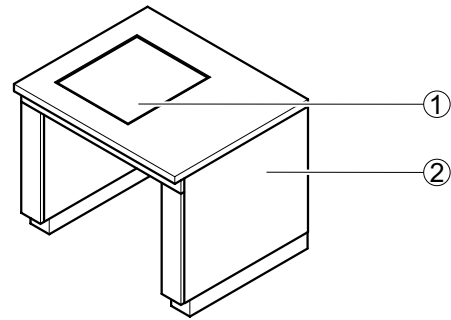

- 1 Balance plate made of fine concrete
2 Table cover

Technical data

Dimensions	
Width [mm]	900
Depth [mm]	750 900
Working height [mm]	750 900
Width x depth [mm] balance plate	400 x 450

Material	
Supporting construction	Steel profile
Worktop	Depending on requirement
Balance plate	Fine concrete

Weight	
Total weight [kg]	120
Balance plate [kg]	65

Design characteristics	
Construction	Specially mounted, heavy balance plate made of fine concrete Supporting construction with balance plate, vibration-decoupled

Intended use

- Mobile flexible storage area
- Can be used with the 600 mm deep shelf as a mobile workplace for desk work
- Not suitable for storing hazardous substances

Design

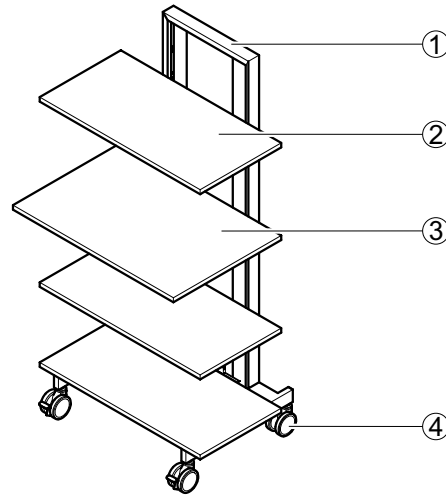

- 1 Steel support frame with grid
- 2 Shelf, depth 450 mm
- 3 Shelf, depth 600 mm
- 4 Heavy load castors with brakes

Technical data

Dimensions	
Width [mm] with shelf	900
Depth [mm] with shelf depth 450 mm	600
Height [mm]	1790
Depth, shelf [mm]	450 600

Material	
Supporting construction	Steel profile
Shelf 22 mm	Shelf of OSB board

Load bearing capacity	
Total [kg]	150
Shelf [kg]	20

Design characteristics	
Heavy load castors	4, of which 2 can be locked (castor and steering axle can be locked)
Shelf	Can be adjusted without tools with a pitch of 150 mm
Integrated distribution pillar	Optional

Special tables

Heavy duty rack

Intended use

- Mobile multi-stage storage area
- With flexible work surfaces for free horizontal configuration
- Suitable for accommodating stackable and non-stackable measuring instruments / measuring instrument towers
- Suitable for heavy apparatus

Design

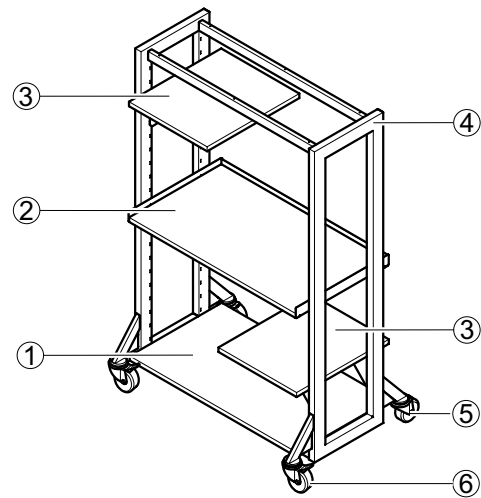

- 1 Lower shelf, fixed
- 2 Height-adjustable shelf, full width
- 3 Height-adjustable shelf, depth 590 mm
- 4 Steel support frame
- 5 Heavy load castors without brake
- 6 Heavy load castors with brake

Technical data

Dimensions		
Width [mm]	1200	1800
Depth [mm]	770	
Height [mm]	1790	
Shelf, width x depth [mm]	500 x 590 1072 x 590	500 x 590 1672 x 590

Material	
Supporting construction	Steel profile 70 x 40 mm
Shelf	Shelf of OSB board

Load bearing capacity	
Total	500 [kg]
Shelf 500 x 590 [mm]	30 [kg]
Shelf 1072 x 590 [mm]	70 [kg]
Shelf 1672 x 590 [mm]	70 [kg]
Lower shelf 1072 x 590 [mm]	150 [kg]
Lower shelf 1672 x 590 [mm]	150 [kg]

Design characteristics	
Heavy load castors	4, of which 2 can be locked (castor and steering axle can be locked)
Shelf	Can be adjusted with a grid of 75 mm

Intended use

- Bench frame with worktop made of various materials as a work surface and storage area for laboratory work
- Supporting construction for analytical equipment and superstructures
- Visually appealing connection of laboratory benches of different depths

Design

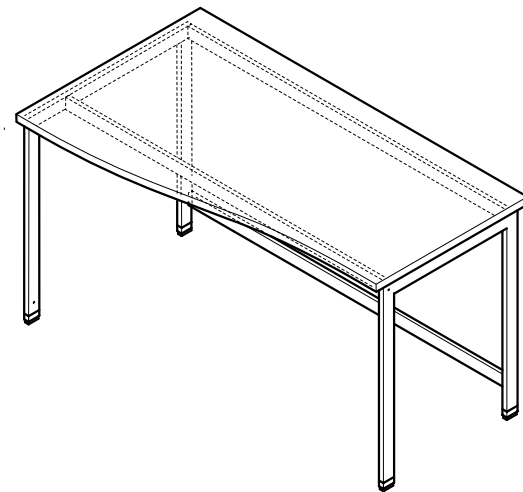

Technical data

Dimensions		
Width [mm]	1200	1500
Depth [mm]	600 – 750 750 – 900	
Working height [mm]	750 900	

Material	
Bench frame	Steel profile 60/25/2 mm
Worktop	Depending on requirement
Height-adjustable feet	Plastic housing with steel spindle

Load bearing capacity	
Total [kg]	200

Special tables

Height-adjustable table

Intended use

- Bench frame with worktop made of various materials as a height-adjustable work surface and storage area for laboratory work
- Supporting construction for analytical equipment and superstructures

Design

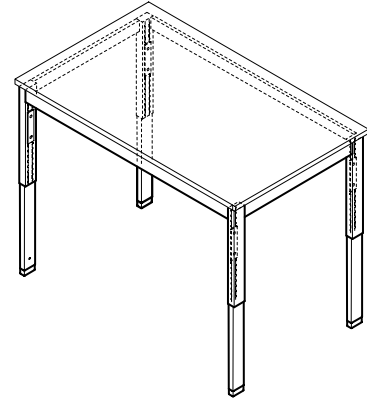

Technical data

Dimensions		
Width [mm]	1200	1500
Depth [mm]	600	750
	900	
Working height [mm]	700 – 950	

Material	
Bench frame	Steel profile 60/25/2 mm
Worktop	Depending on requirement
Height-adjustable feet	Plastic housing with steel spindle

Load bearing capacity	
Total [kg]	200

Design characteristics	
Working height	Can be adjusted with a grid of 25 mm
Bench frame	H-frame

Special tables

Round table

Intended use

- For adding to benches with H-frames and C-frames as an additional work surface

Design

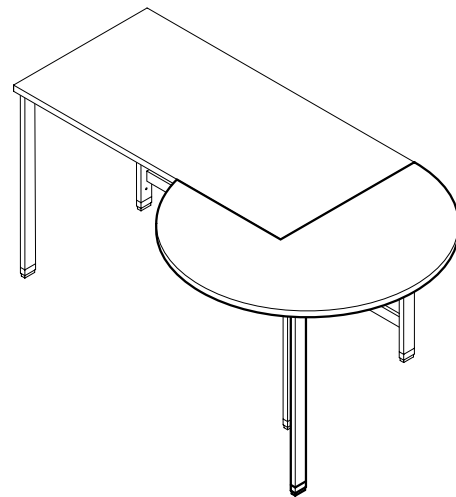

Technical data

Dimensions	
Diameter [mm]	1200
Working height [mm]	750 900

Material	
Bench frame	Steel profile 60/25/2 mm
Worktop	Depending on requirement
Height-adjustable feet	Plastic housing with steel spindle

Load bearing capacity	
Round table [kg]	50

Special tables

Sliding element Sekretär

Intended use

- Inclined desk that can be moved on a laboratory work bench

Design

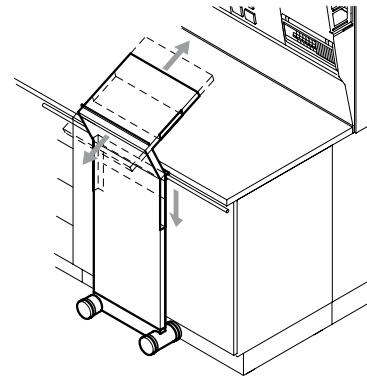

Technical data

Dimensions	
Width [mm]	416
Working height, bench [mm]	900
Max. overall height [mm]	1244

Design characteristics	
Construction	Sliding element on 4 wheels Fastened to a sliding rail on the laboratory work bench with an adjustable writing pad

Material	
Sliding element	Particle-board with melamine resin facing in walnut veneer

Intended use

- Fold-out storage area and desk that can be moved on a laboratory work bench

Design

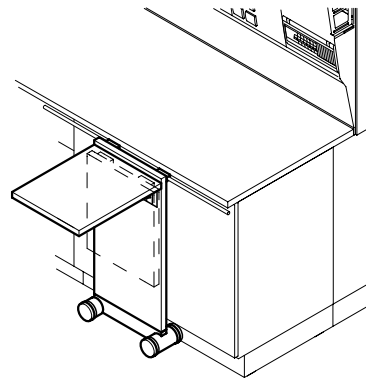

Technical data

Dimensions	
Width [mm]	406
Depth [mm]	530
Working height, bench [mm]	900

Load bearing capacity	
Storage area and desk [kg]	10

Design characteristics	
Construction	Sliding element on 4 wheels Fastened to a sliding rail on the laboratory work bench Can be folded down completely

Material	
Sliding element	Particle-board with melamine resin facing in walnut veneer

Special tables

Sliding element Protector

Intended use

- Protection from splashes and splinters that can be moved on a laboratory work bench

Design

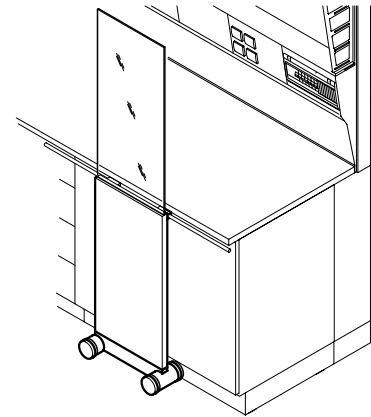

Technical data

Dimensions	
Width [mm]	406
Working height, bench [mm]	900
Overall height [mm]	1780

Design characteristics	
Construction	Sliding element on 4 wheels Fastened to a sliding rail on the laboratory work bench

Material	
Sliding element	Particle-board with melamine resin facing in walnut veneer
Splash protection	Safety glass

Laboratory benches and sinks